

# Active Voice and Raising

## Linguistics 322

### 1 Intermediate Syntax

Voice is a grammatical category, an operator, that has no directly link to conceptual structure. Voice is a complex issue, but it appears to mark a prominent object that the speaker chooses to make prominent. In English there are three voices: active, passive, and middle. The active voice is the unmarked voice; it is opposed to both the passive and the middle voices. The middle voice is the marked voice. It is more restricted than the passive and occurs less frequently:

- (1) a. John is reading this book. (active)
- b. This book is being read by John. (passive)
- c. This books reads easily. (middle)

The middle and the passive are similarly in that the internal argument is projected to the subject position. They differ in form (the passive requires an auxiliary [dummy] verb), whereas the middle does not. Middles tend to have a generic reading or indicate a property of the subject as in (3) above. We will not cover the middle voice in depth here, preferring to concentrate on the passive voice once we have covered the active voice.

The active voice is the unmarked or default voice: [-Passive]. Virtually every verb may occur in the active voice--indeed some of them must:

- (2) a. John ate the potato.
- b. Some birds are flying.
- c. Henry resembles Hank's father.

The passive voice is restricted to transitive verbs. There is a small class of transitive verbs that cannot be marked in the passive voice.

- (3) a. The potato was eaten by John.
- b. \*Be flying some birds.
- c. \*Hank's father is resembled by Henry.

Intransitive verbs cannot be passive in English, though they can in German. Apparently, if the subject in the active voice is a theme, the passive voice is not possible.

Let us start with (4); it corresponds to (3a), its active voice counterpart. Both appear to be derived from the same conceptual lexical L-structure:

(4) PASSIVE <EAT <theme: POTATO> <agent: JOHN>>

The tree structure with features for (4) is:

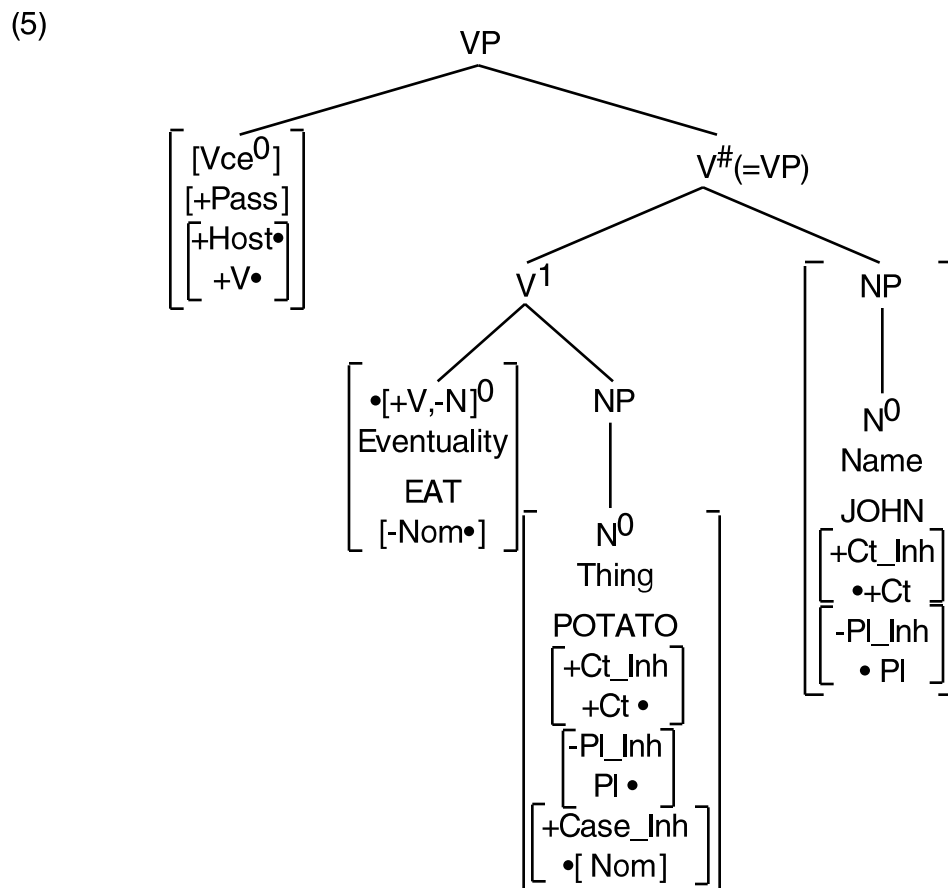

Chomsky proposed that [+V, -N] is a binary feature representation of V. This representation makes it convenient to show the link from [+V] to [+V] below in (6).

Voice is an operator, modifying the verb in its scope. The evidence of English syntax shows that this operator is closest to the main verb. No other auxiliary verb or overt operator may occur between the auxiliary verb {BE} associated with the passive voice and the main

verb. If this is correct, then we may claim that voice subcategorizes a main verb, a predicate adjective, or a preposition, all of which are linked to eventualities. The structure containing voice and its argument is a phrase, which we may call a voice phrase (VceP), or we may consider it to be an extension of the verb phrase (VP), prepositional phrase, or adjective phrase. The latter we chose here. If features such as Eventuality and its subparts, Thing and its subparts are considered lexical features as well as propositional features, then we can modify (8) to the following simpler form. Both NPs are simplified here except for Case which is not simplified:

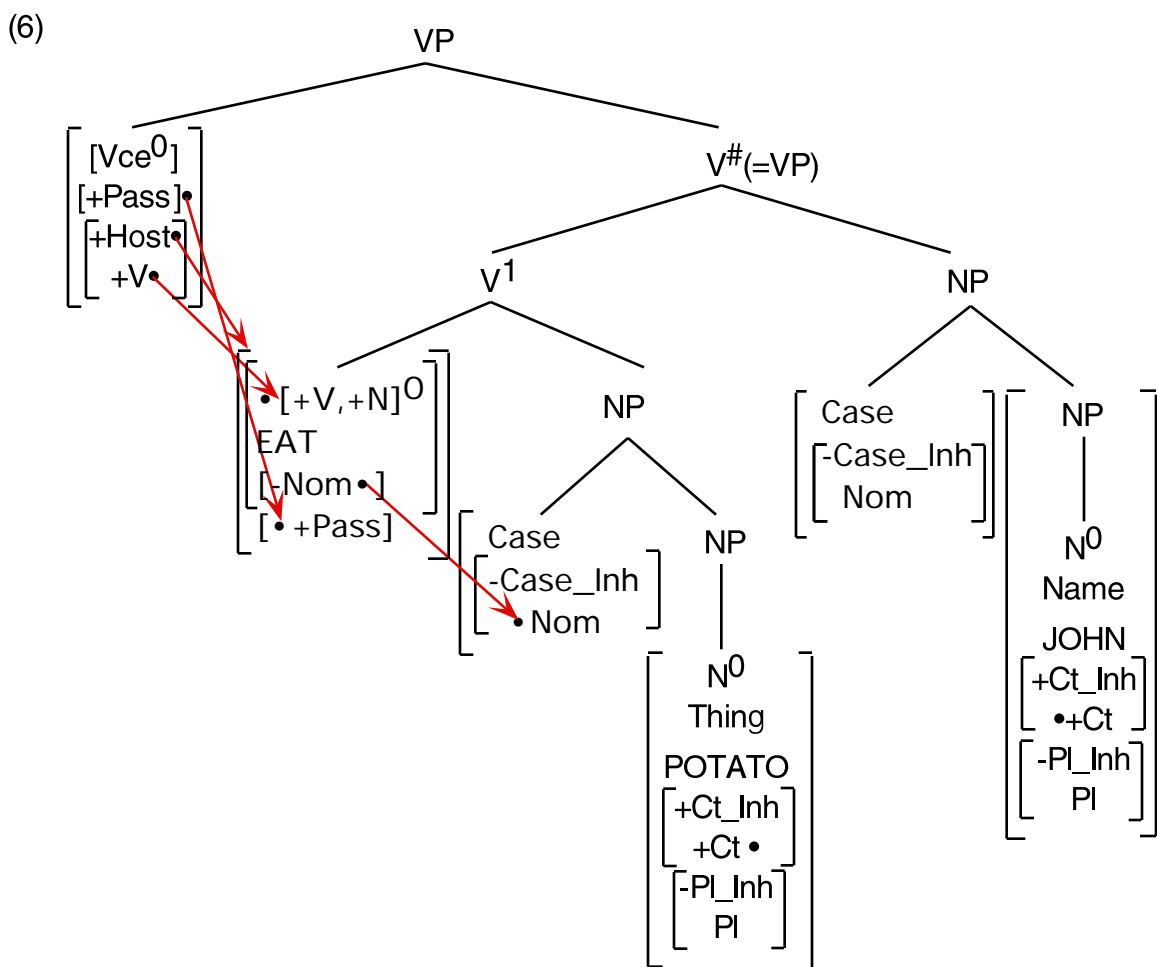

[+Passive] requires a verbal host. The feature must govern the to which it will be adjoined. If not, the feature could be adjoined to any verb in a complex sentence:

- (7) a. John told Mary that he likes horror movies.  
b. Mary was told by John that he likes horror movies.  
c. \*Mary told by John that he is liked horror movies.

In (7c) the feature [+Passive] in the upper clause triggers the correct positioning of noun in the upper clause, but the feature is adjoined to the verb in the lower clause which the feature does not govern. The feature [+Host] must be accompanied with a feature indicating which category is targeted: [[+Host]; [+V, -N]]

[+Host] is a feature found in all affixes, which means that they need a host, to which they will be adjoined. [+Passive] and most of the other verbal operators need a host. Tense, Relevance, Aspect, and Voice need a verb as a host. To accomplish this, the passive feature is copied to and adjoined to the verb which it governs. Later, we will see that a dummy verb will be required if the main verb is not available for hosting.

## 2 Case

In the active voice JOHN, which has no Case, is raised to the subject position PROM, where it will be assigned the nominative Case [-Nom]. POTATO receives its Case marking by agreement from the verb. This completes the active voice.

## 3 Prominence

In the passive voice, it is POTATO that is raised to the subject position. How does this come about? First, recall our proposal for the subject as a basic node of syntax, whose complement is tense. Although it is far from certain, it has been proposed that the function of the subject is to bring one of the arguments of the main predicate into prominence. It appears that prominence brings more attention to targeted for prominence. This seems to be a reasonable proposal and we shall adopt it here.

Adopting it, the subject NP in the active voice is copied (raised) from the external argument (the ungoverned argument) of the verb. This is the default. Furthermore, in English one argument must be raised to the subject position--i.e. one argument must be prominent.

There are some exceptions to this, but only in certain predictable cases. We will work with the case where one argument must be raised here.

We take the view that voice is concerned with prominence. In many if not most languages, one of the arguments of the verb must be marked as prominent. The features of the prominent argument, usually a NP, are copied to the subject position. (See 322.subject.htm.) There are three voices in English; we will be concerned here with the first two: the active and the passive: [ $\pm$ Pass]. The passive is the marked, or restricted, voice, in that in English only transitive verbs can be marked for the passive voice. Passive verbs can be derived from intransitive verbs. The third voice, the middle voice, is not covered here.

#### 4 Targeting

In the active voice the external argument is targeted; this is the default for English and apparently all languages. Case plays a role in targeting. Only a NP that is unmarked for Case can be raised to the subject position. In the subject position, the nominative Case is assigned to the subject.

In structure (6) the external argument is targeted. We mark the feature of targeting here as the second part of the hosting feature doublet. Two things must happen now. The targeted NP remains unmarked for Case (the intermediate operators are omitted here for the sake of brevity). This means that the targeted NP must raise to the subject position. We mark this with the feature [ $+$ Prom], copied from the prominence (subject) node. Note we have assigned the feature [ $+$ Prom] to the maximal node NP, not to the head N or any of the intermediate projections. This means that all the features of the NP must be copied to the subject position.

A link is established between the phrasal nodes containing the features [ $+$ Prom] as a result of copying. It is through this link that the features are copied. The intermediate operators of the verb are omitted in the following diagram:

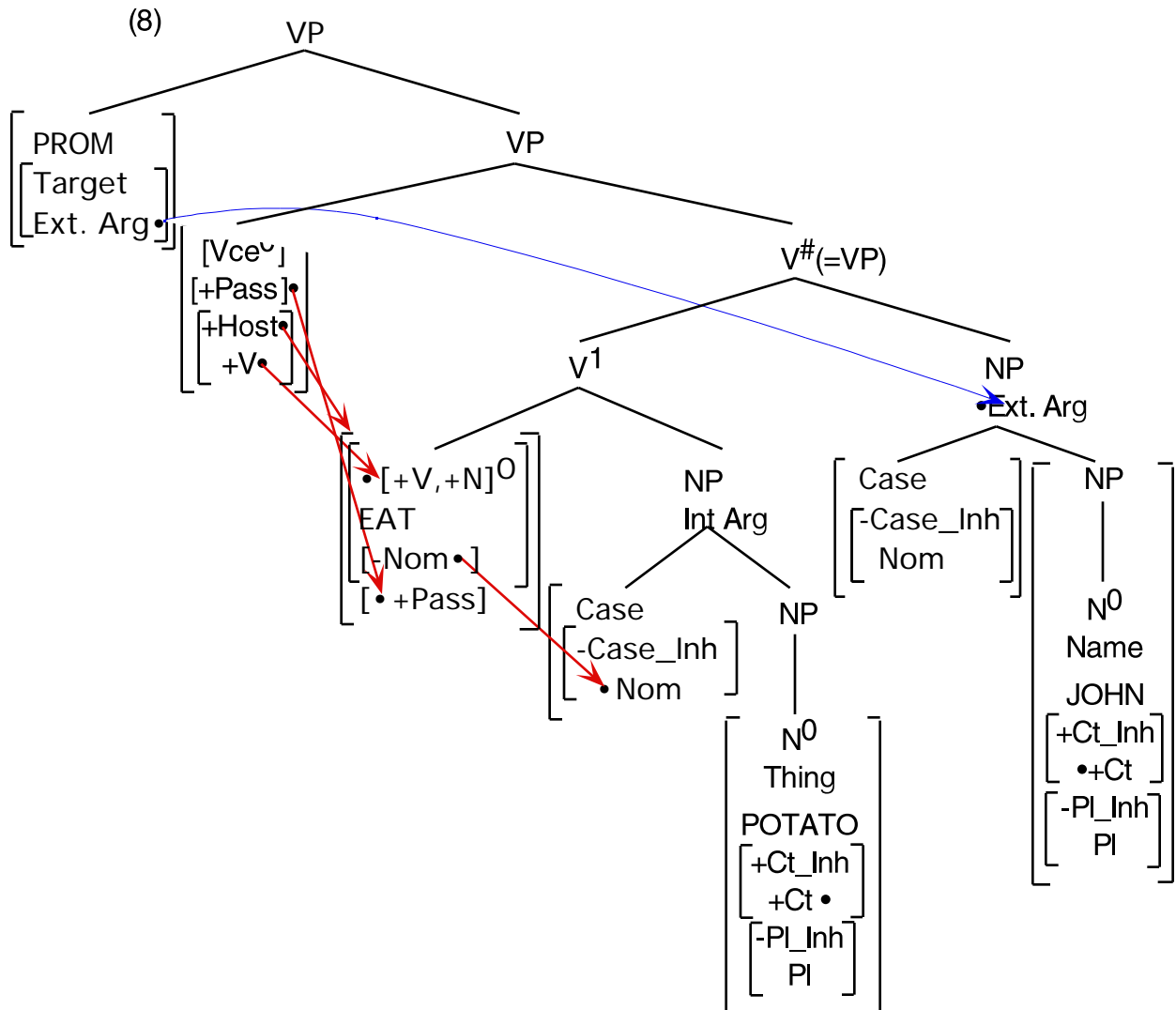

To add a bit more detail. [TRACE] is the term used for the tail end of a link, if the tail is phonetically null, which it is here.

Let us say that the subject position is marked [+Nom]. We will discuss the source of [+Nom] later. The features of the NP marked [+Prom] are copied back to PROM. These features are adjoined to PROM. Since they are now marked with [+Nom] (assigned the nominative Case), they can be spelled out. Normally, tail of a PROM link is spelled out, thus establishing the basic word order of the English sentence:

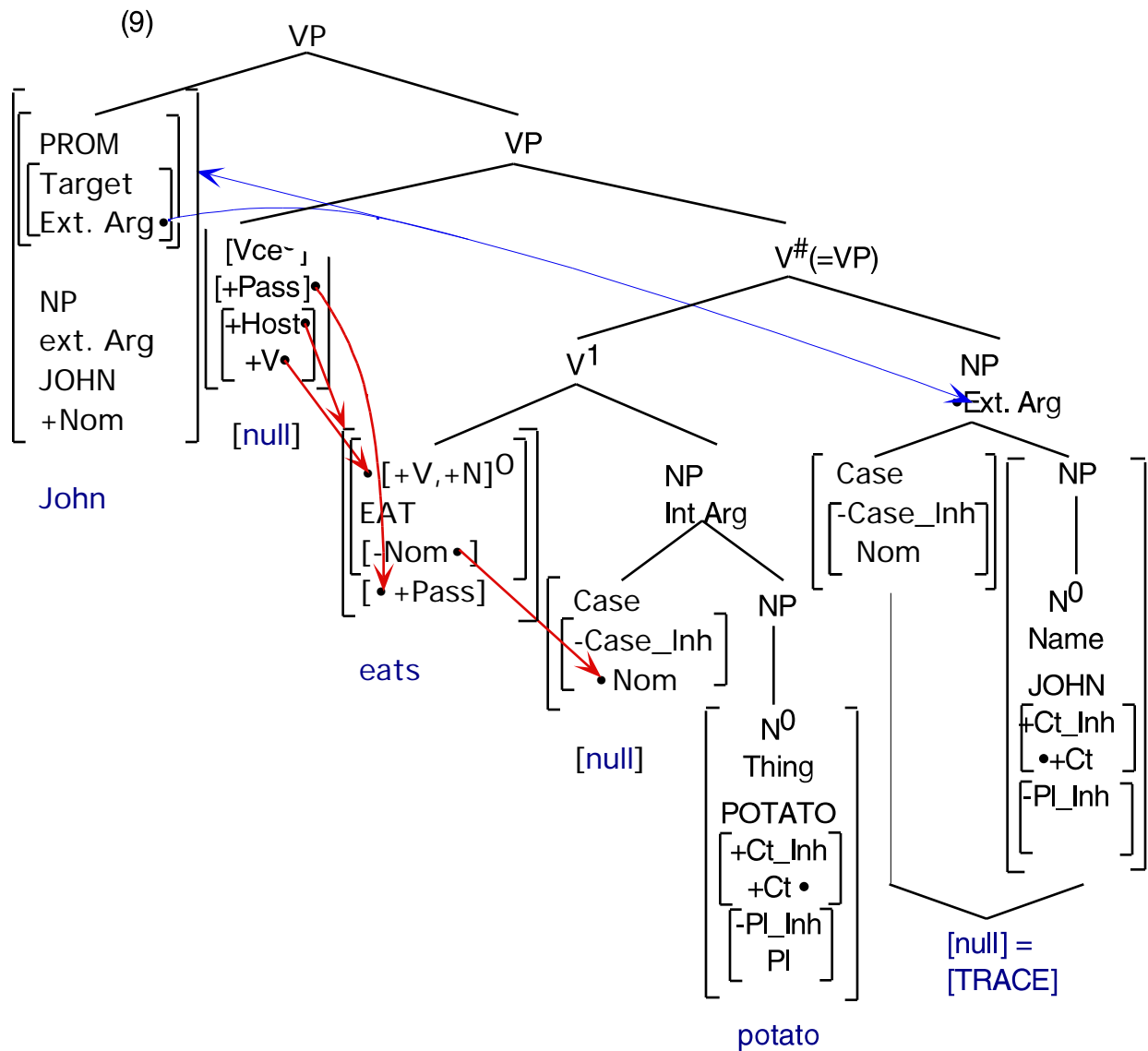

The link from PROM to the external argument and the link back are not exactly the same link. The link back through which the features of NP are copied points to feature bundle containing PROM; consequently the features of NP are adjoined to Prom.

At this point our discussion of syntax takes a heretical turn. Chomsky argues that the NP is raised so that it may be assigned Case. Although we agree it must, we contend that raising is motivated by [+Prom]. Note in the structure above, Case must agree in the head and the tail. It thus follows that the tail must also be marked [+Nom] through head-to-head

agreement. As in the case of feature bundles requiring a host, they can only be spelled out as [null] in the tail position, which is not prominent.

The link holding between the trace NP (the tail) and SP (the head). This is not a typical government link, and we indicate this in blue. The relation between the head of this link and the tail of it as been called an antecedent government by Rizzi. Antecedent government holds between the maximal projection of the head and the maximal project of the tail:

- (10)            Antecedent Government
  - a.    X antecedent-governs Y iff
  - b.    a. X governs Y
  - b. The features of X are coindexed with the features of Y.

Unlike feature linking, antecedent government links all the features of the maximal project as a bundle between the tail and the head. The different types of government do not interfere with each other. One cannot act as an intervening governor for the other.

This page last updated 21 FE 03